

OPERATING INSTRUCTION

LOUDSPEAKER

No.8.3

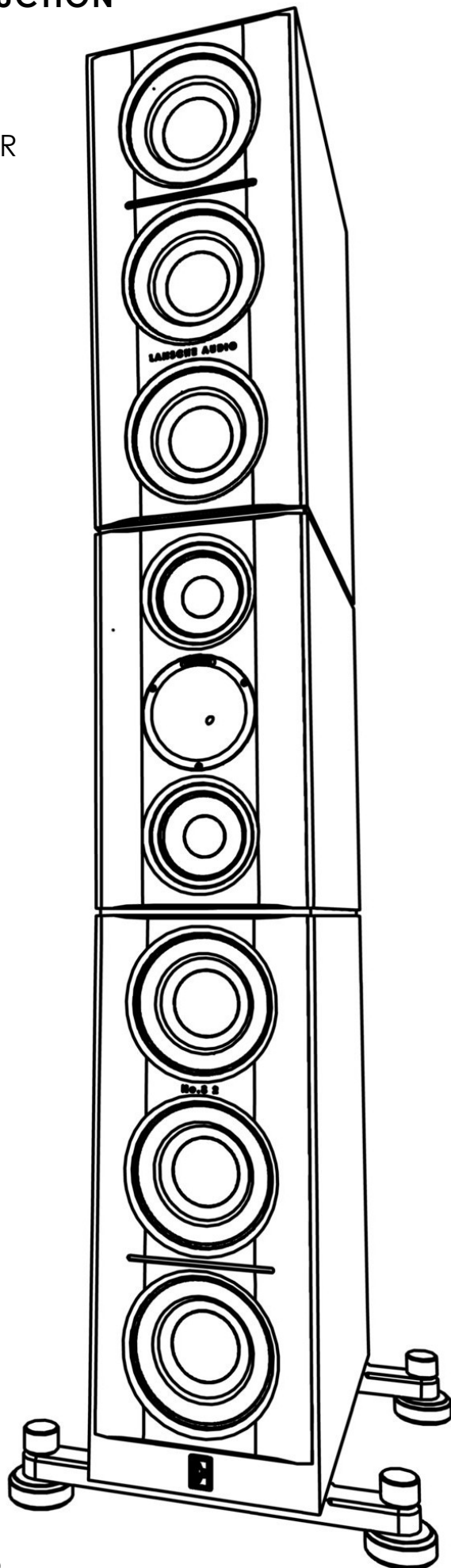

LANSCHE AUDIO

OPERATING INSTRUCTIONS No.8.3

1. Unpacking the Speakers	3
1.1. Unpacking Lower part	4
1.2. Unpacking Upper part	6
1.3. Installing	7
2. Operating and Connecting Components	11
2.1. Overview	11
2.2. Positioning the Speakers	12
2.2.1. Acoustic alignment of the speakers	12
2.2.2. Distance between the speakers	13
2.2.3. Feet	13
2.3. Connecting the Speakers	14
2.3.1. Connecting the amplifier (single)	14
2.3.2. Connecting the amplifier (bi-amping / bi-wiring)	15
2.4. Operating the Speakers	16
3. CORONA Plasma Tweeters	16
3.1. Information about CORONA Plasma Tweeters	16
3.2. Self-starting	17
3.3. Maintenance	18
3.4. Removing and Installing a CORONA Plasma Tweeter	18
3.5. Cleaning procedure	19
3.6. Fan system	20
3.6.1. Control of the ventilation grille	20
3.6.2. Replacement fan	20
4. Miscellaneous Instructions	20
4.1. Warm-Up Phase	20
4.2. Load Rating	21
4.3. Caring for your Speakers	21
5. Technical Specifications	21
6. General Notes on Safety	22

Dear Connoisseur of Great Sound!

We sincerely appreciate the trust you have extended to us in purchasing this Lansche product, and we would like to congratulate you on your fine selection. In choosing this high-quality speaker system, you have proven your elevated standards for craftsmanship and sound reproduction. This speaker system unites sound fidelity, uncompromising quality, and technical innovation with an extraordinary degree of flexibility. In order to achieve the best possible sound experience, please read these instructions carefully. Be sure to keep these instructions in a safe place for future reference.

If you still have any questions, please feel free to consult your dealer or inquire directly with us.

We at LANSCHE AUDIO would like to wish you a very enjoyable listening experience.

1. Unpacking the Speakers

Please exercise care when unpacking LANSCHÉ AUDIO speakers and accessories. Because of their weight and size, we strongly recommend using the assistance of another person. This will help to avoid damage to the devices or to people when unpacking and setting up your speakers.

The following parts are included in the package:

- 4 x speaker cabinets
- 2 x power supply cables
- 1 x operating instructions
- 2 x cable bridges
- various tools

1.1 Unpacking Lower part

1. Position the wheels crosswise and apply the brake

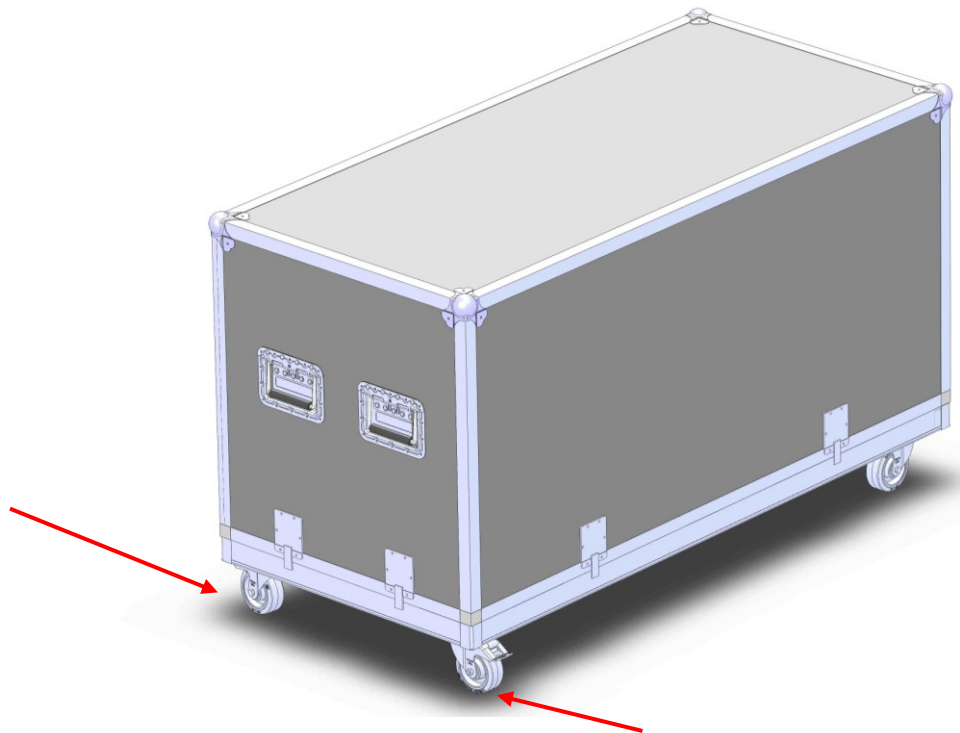

2. Release the fasteners on the flight case that secure the cover to the lower section and carefully lift the upper cover

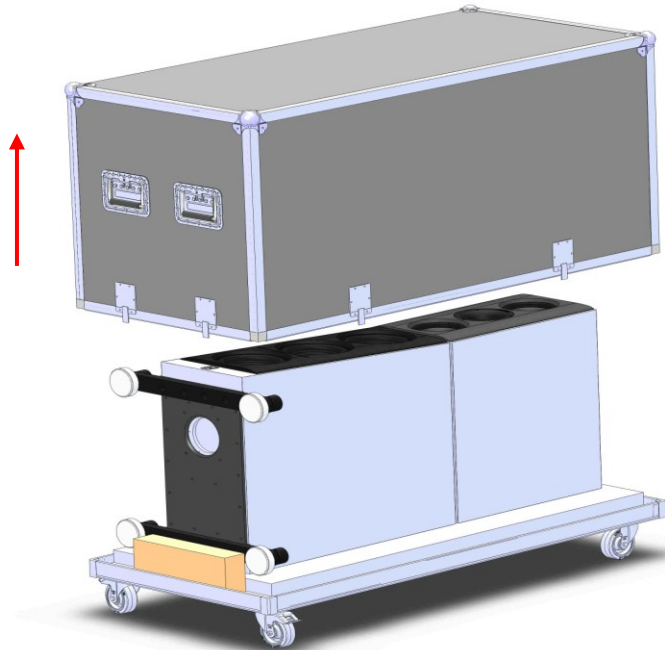

3. Turn the base upright. Be careful that the speaker cannot fall forward uncontrollably when it is turned upright by more than 90 degrees. A soft base is helpful

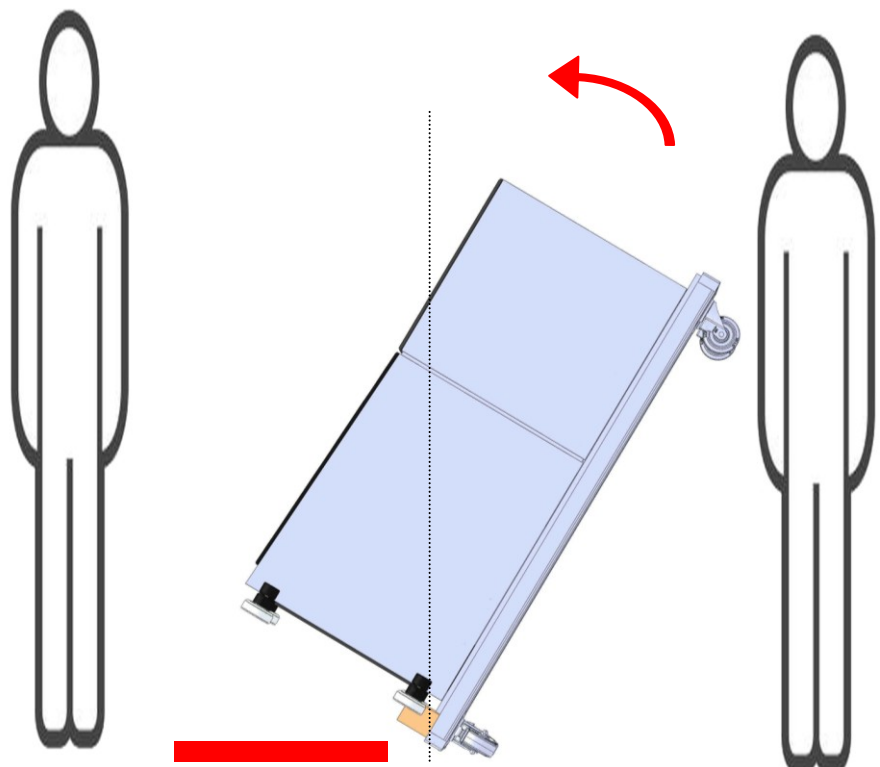

4. When the speaker is placed on its front feet, remove the base.
Caution: It must be ensured that the speaker does not tip backwards in an uncontrolled manner when the base plate is removed.

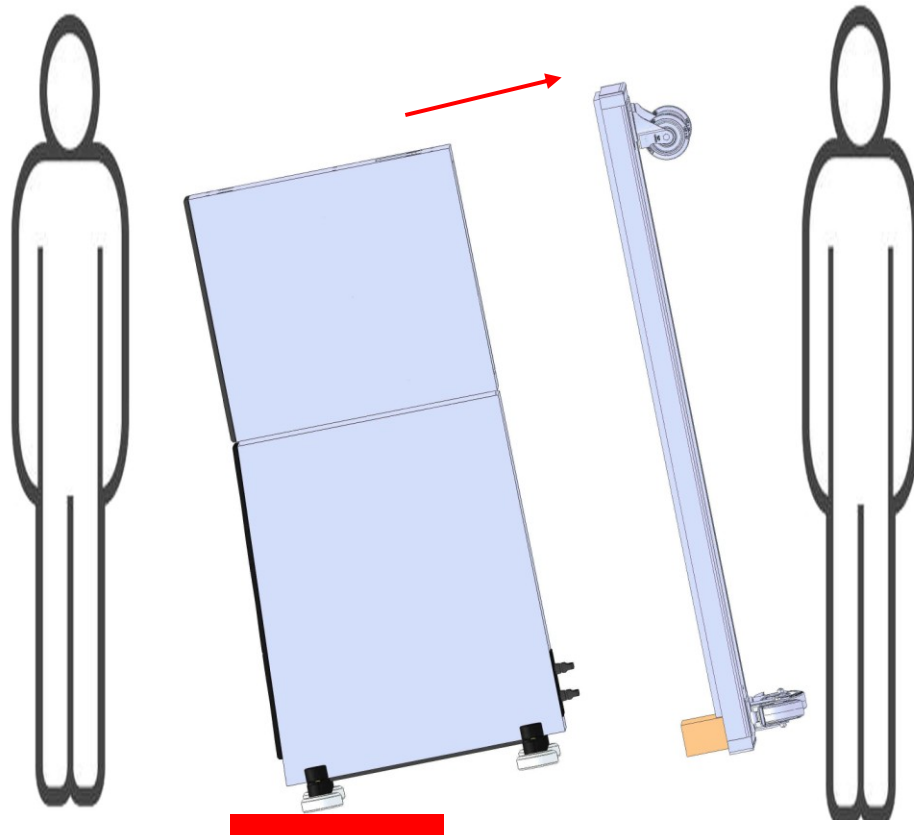

5. Carefully place the speaker completely on the floor
Important: The bottom part is labeled with a "1" or a "2".

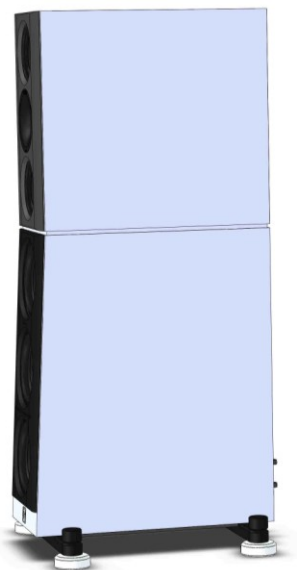

1.2. Unpacking Upper part

1. Carefully remove the cover of the flight case.
There are two top parts in the case.
Important: They are labeled with a "1" and a "2".
They belong to the lower part labeled "1" or "2" so that
the veneer pattern is continuous.

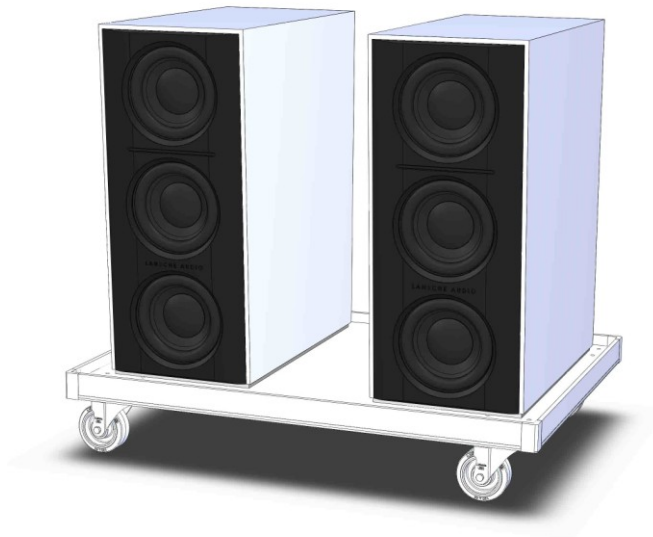

2. The accessory case contains four vacuum lifters.
Attach these to the side of the loudspeaker.



3. Using four suitable people, carefully place the upper part onto the corresponding lower part.

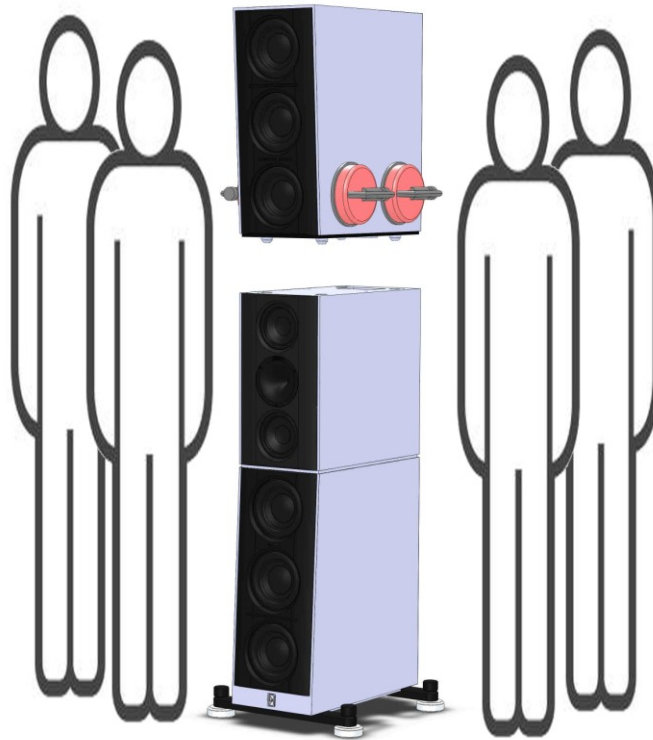

1.3. Installing

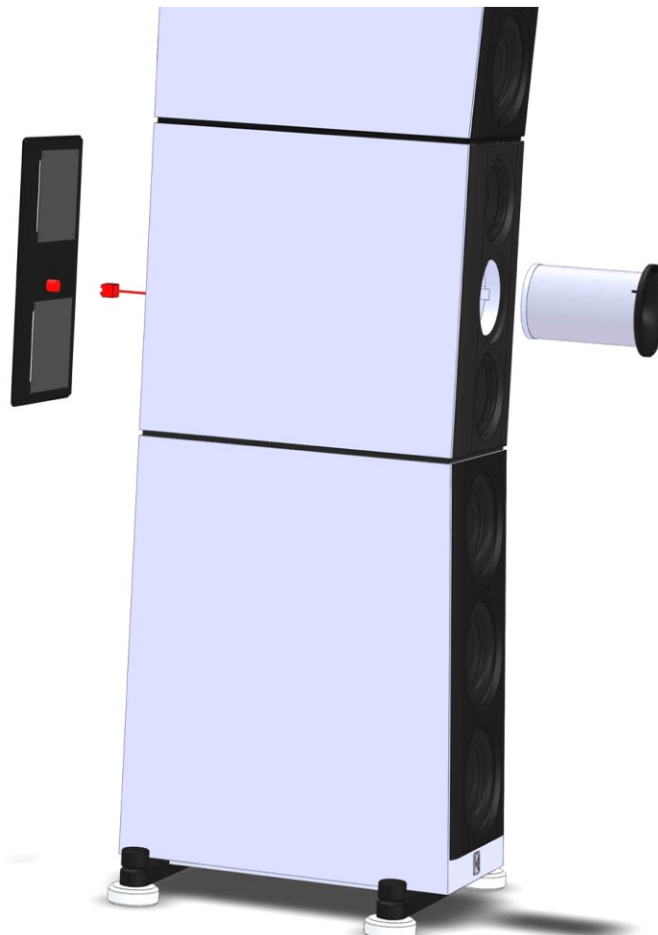

1. Remove the plasma tweeter (Allen key 2.5 mm) and disconnect the two-pole RCA cable and the connection for the power supply.

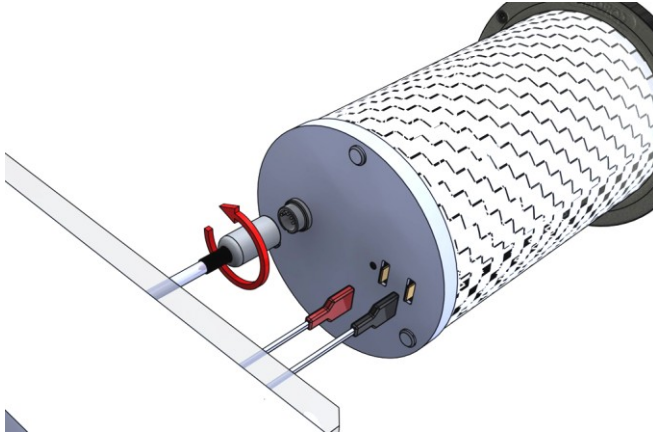

Take out the rear panel (3.0 mm Allen key) and remove the cable for the power switch. The appropriate tools are included in the accessory case

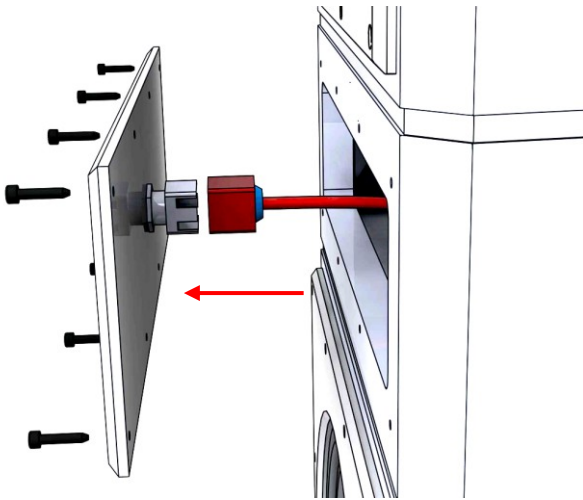

2. Screw the upper section to the lower section.
There are 4 screws with washers in the accessory case.
Attach them to the intended positions.
(The picture shows the speaker without the side panel)
The front two screws are already integrated and must also be connected to the upper part.

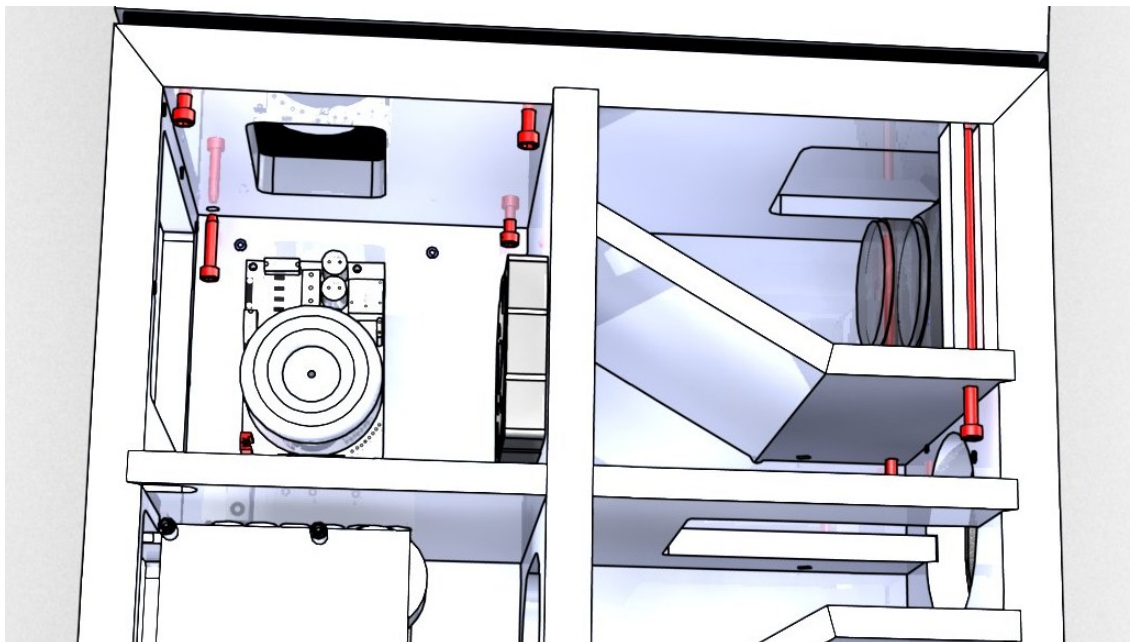

3. Connect the eight-pin Speakon plug to the upper part.

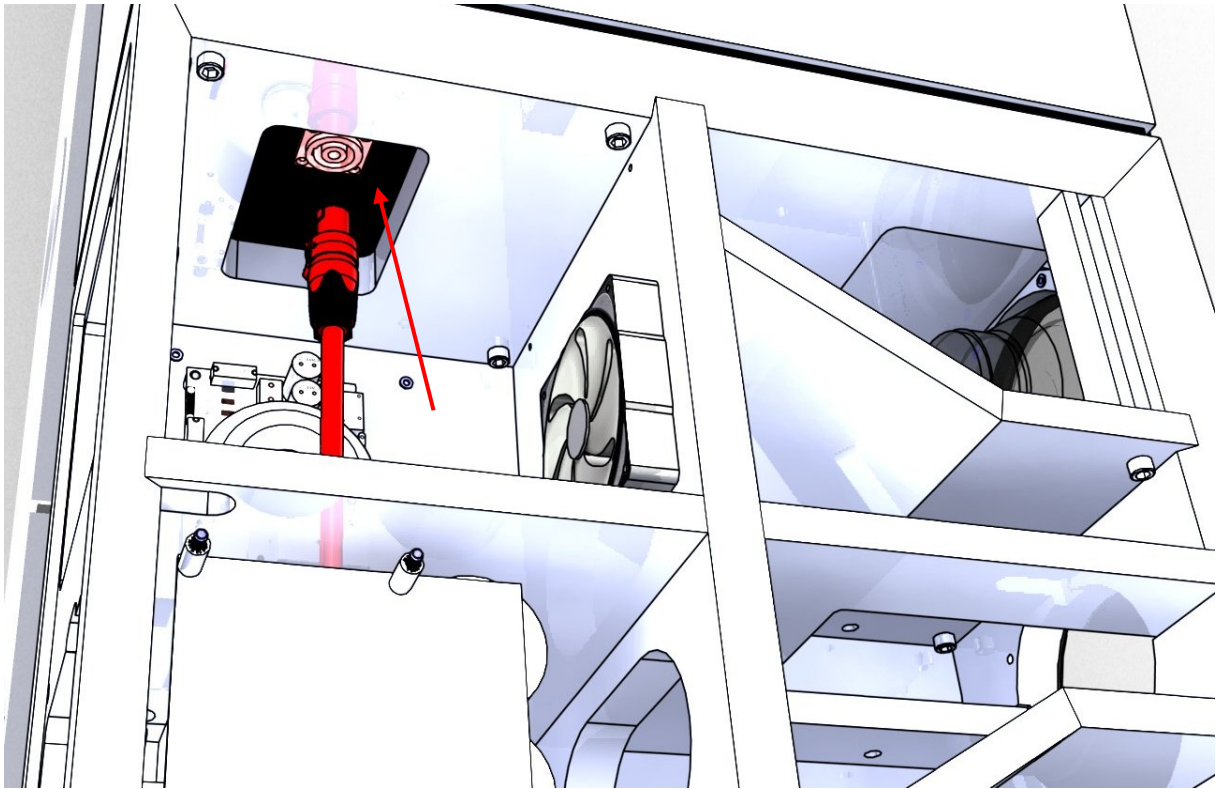

4. The silver slider of the Speakon connector must show to the rear

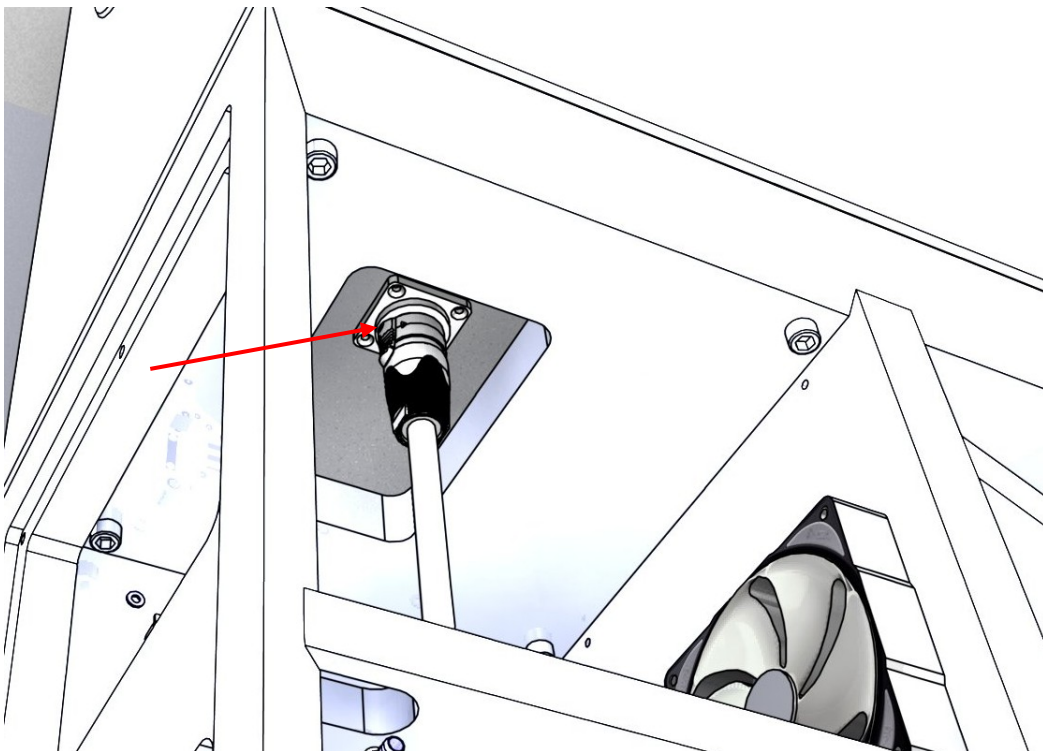

5. Reconnect the plasma tweeter with the two-pole RCA cable. (the connection for the red cable is marked) .Connect the plasma tweeter to the power supply cable. (Insert into the socket and then secure with the twist lock). Replace the plasma tweeter and secure it with the three screws.

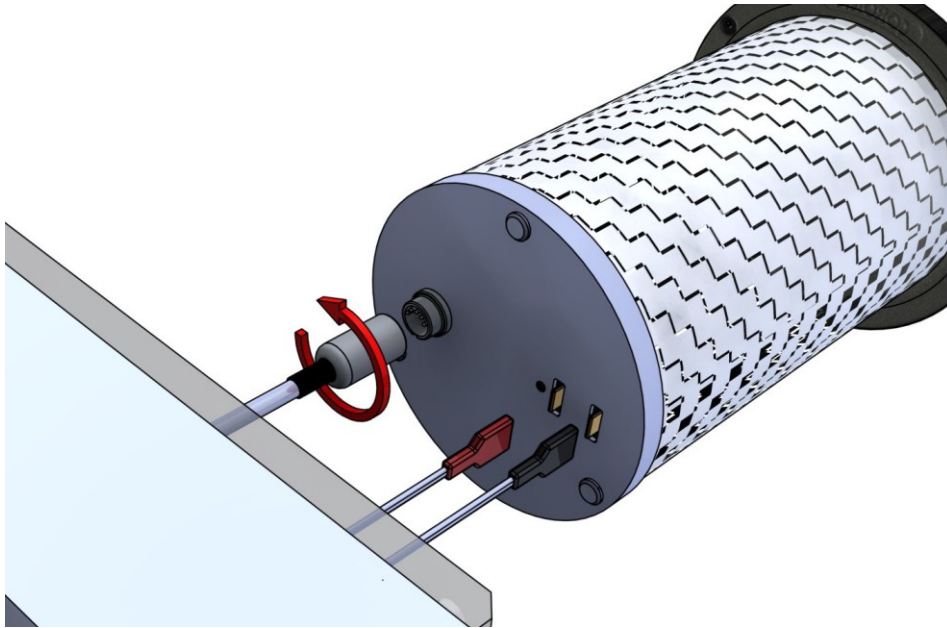

6. Connect the rear panel to the cable for the power switch. Insert the back panel and secure with the screws.

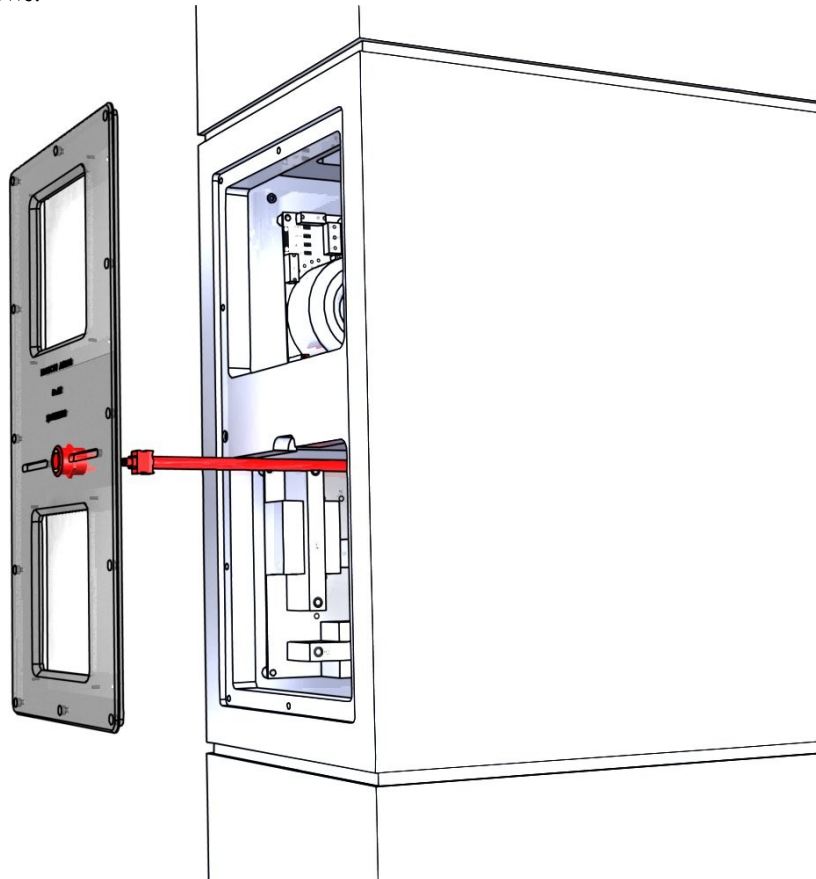

7. The loudspeaker is now ready for operation

2. Operating and Connecting Components

2.1. Overview

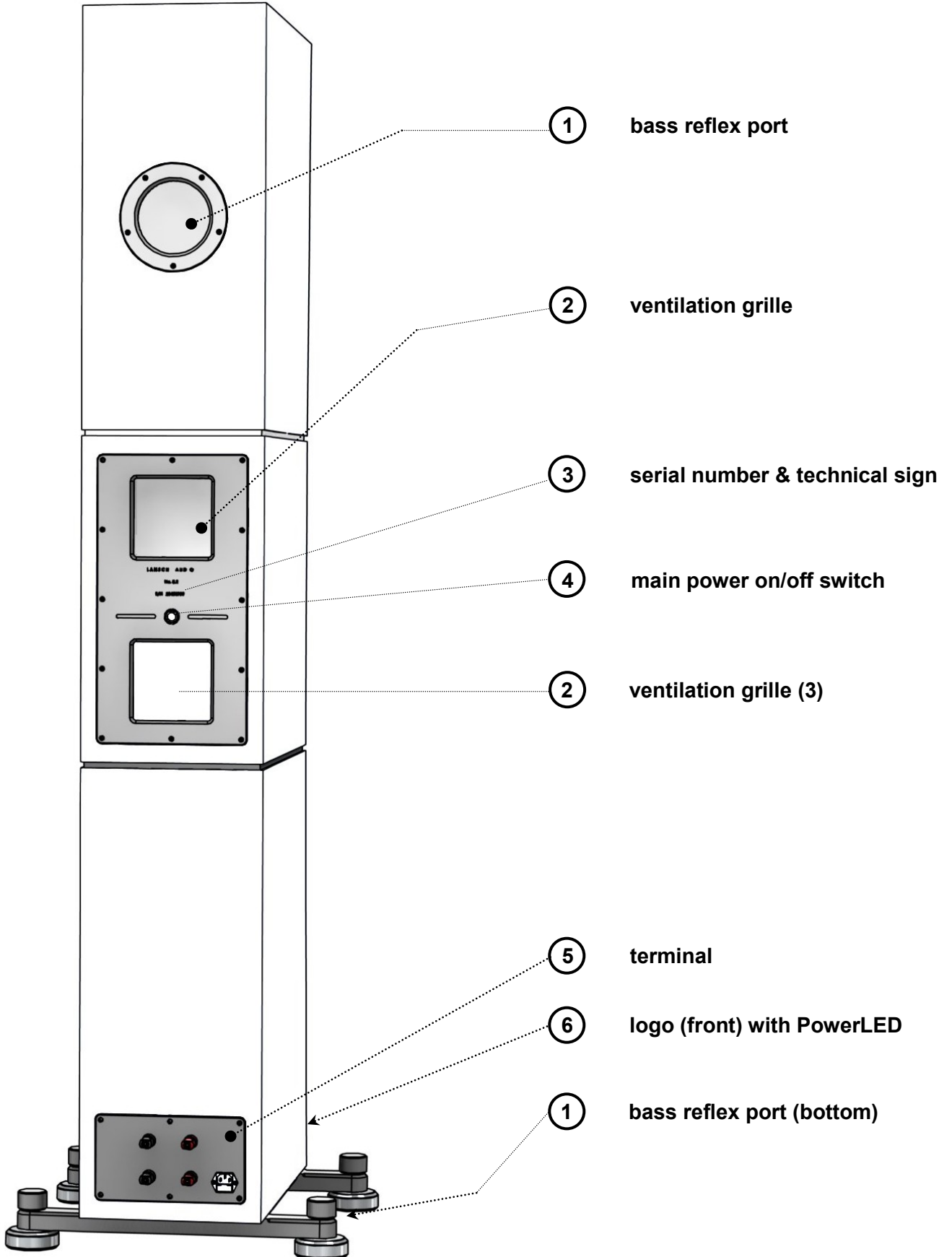

- Terminal (5) -

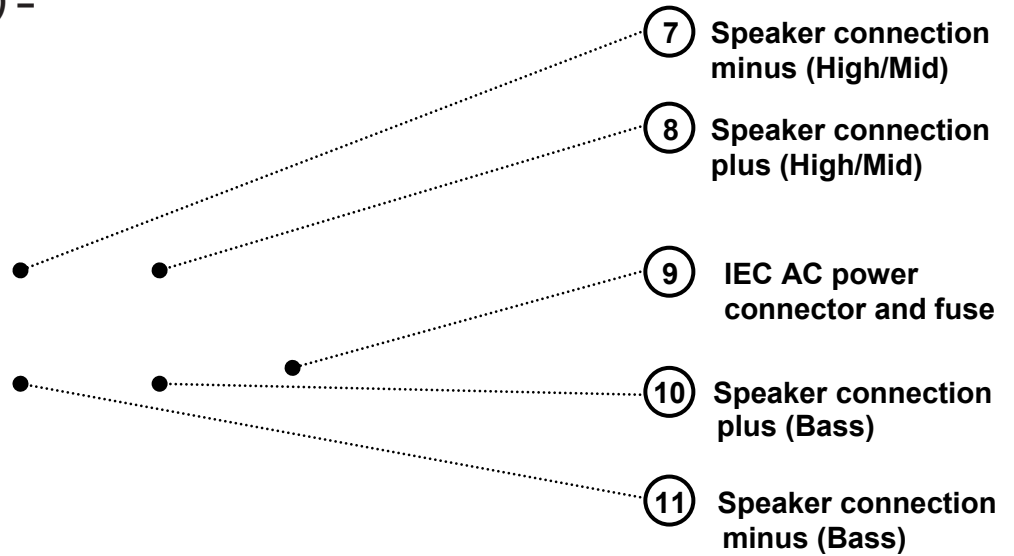

2.2. Positioning the Speakers

NOTE:

The following instructions are intended as guidelines to help you position the speakers in a suitable way.

2.2.1 Acoustic alignment of the speakers

LANSCHÉ No.8.3 speakers should be placed at least 20 cm from the back wall, with a slight inward angle of 5° to 8° to make sure they are not positioned parallel to the wall behind them. Due to reasons of sound propagation, placing the speakers close to the wall will adversely affect the sound quality. The walls reflect the sound, which is perceived by the listener slightly later than the direct sound emission, thus distorting the main sound signal. The best way to position your new speakers is to set up a so-called "stereo triangle". This is accomplished by arranging the speakers such that they create an equilateral triangle, with the listener in the third position (equal distance between all points).

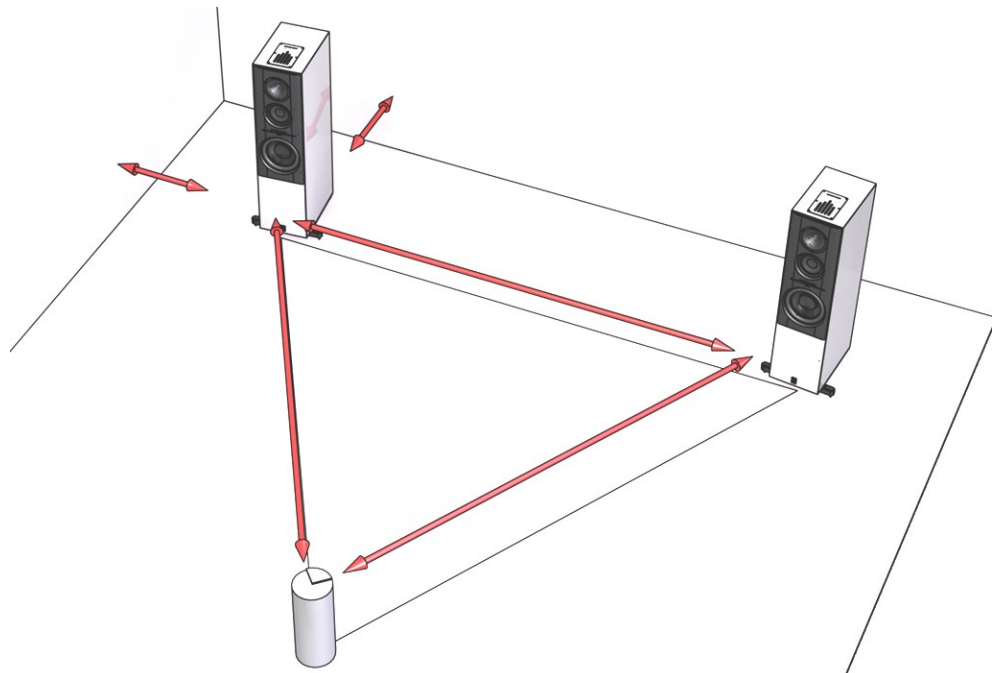

2.2.2. Distance between the speakers

The distance between the speakers for a stereo setup depends on the given distance from the listening position. The distance between the two speakers should be slightly less than the distance to the listening position. Thus, the closer you are to the speakers, the closer the speakers should be to each other.

For optimal positioning, start with a basic distance of two meters, which is then adapted according to the actual room dimensions.

If the speakers are too close, the stereo effect is hampered; if they are too far apart, sound is mainly perceived as coming from either right or left, with an acoustic 'gap' in the center.

It can be helpful to playback a recording whose spatial arrangement you are familiar with when setting up the speakers.

Tip:

If possible set your amplifier to "mono." This allows you to better adjust the center listening position.

2.2.3. Feet

CAUTION:

Floor standing speakers have a high center of gravity and can easily tip over if improperly positioned or bumped. The buyer is responsible for taking the appropriate precautions.

The feet can be adjusted up and down using the top knob. The maximum height difference must not be more than 1 cm or 0.4 inch.

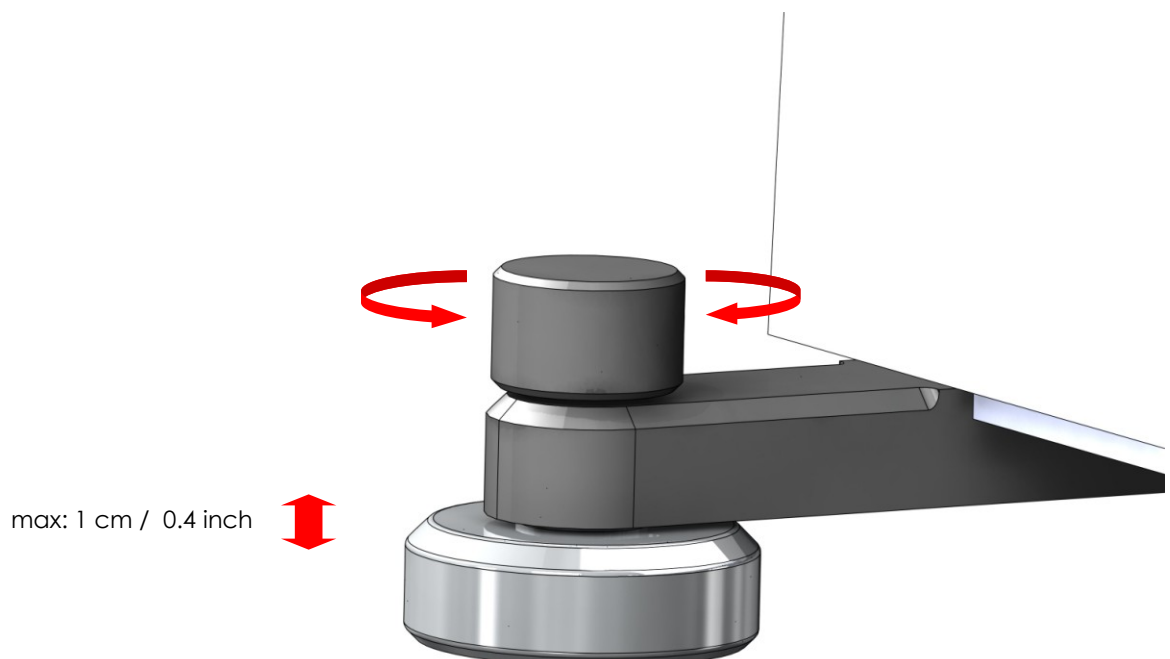

2.3. Connecting the Speakers

CAUTION:

Please turn off your amplifier before connecting any speakers. Supply power to your No.8.3 only after all necessary connections have been made to your audio/video components.

The following types of connections are possible:

- **4.0-mm banana plugs**

Plugged directly into the open sockets. It is not necessary to screw them on.

- **Spades (6mm)**

Fastened by loosening the terminal 'wing nuts' and then tightening the spade firmly onto the gold-plated contact surface.

CAUTION:

Do not tighten the pole terminals with tools.

2.3.1. Connecting the amplifier (single)

For every connection, make sure to maximize the contact area and tightly secure the components to avoid loss of sound quality due to contact resistance. For a continuously secure and corrosion-free connection, the surfaces of all connecting components should also be gold plated if possible. Check to make sure that the stripped cable ends are not touching each other at either the amplifier or speaker. Tighten the screw connections after a few days, as any of the fasteners may have loosened up.

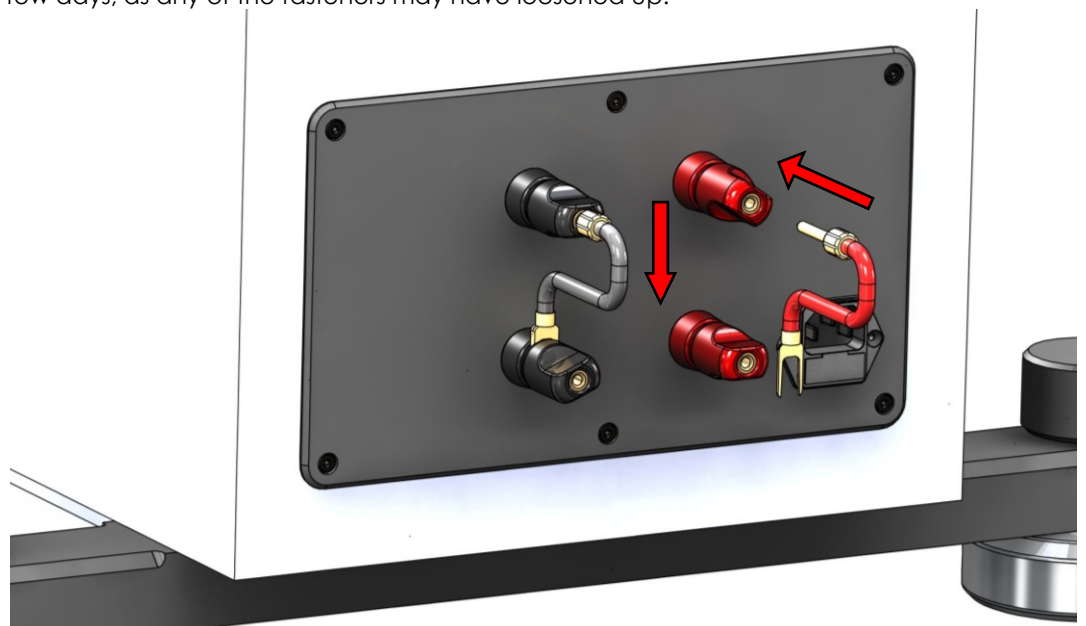

There are 2 cable bridges supplied for each speaker. When using a single wire connection use the bridges as shown on the previous page. This method allows for speaker cables terminated with banana plugs or spade lugs to be used.

When connecting speaker cables, it is absolutely necessary to check for proper polarity: plus to plus and minus to minus. The screw clamps on the loudspeakers as well as the connectors on the amplifier are colour coded and labelled (positive pole = red, negative pole = black). To ensure proper connections, the wires on most speaker cables are also differentiated by colour, form, or marking. Reversing the polarity of the right and left channels results in sound distortions.

In order to avoid short circuiting, the bare ends of the stripped speaker cables should be as short as possible, should not protrude from the screw clamps, and should never be allowed to touch each other. If in doubt, please also refer to the operating instructions of your amplifier.

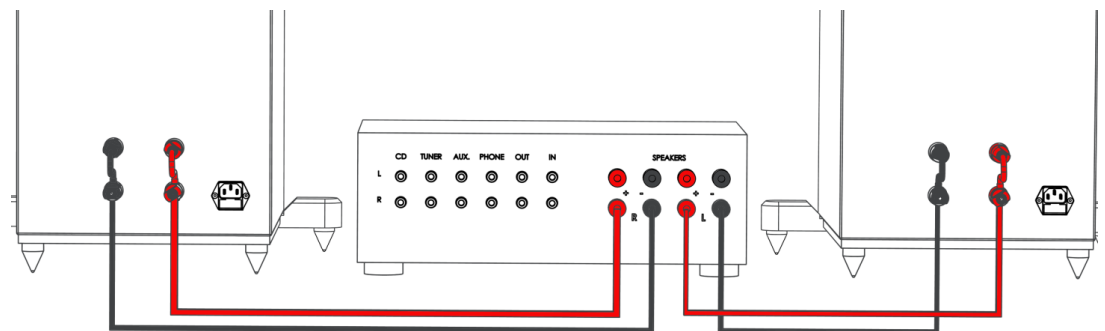

2.3.2. Connecting the amplifier (bi-amping / bi-wiring)

To use bi-wiring or bi-amping first remove any cable bridges from the terminals (7),(8),(10),(11) located on the rear panel (5). Connect your speaker cables as shown in the drawing on the next page.

For bi-amping use either: 4 mono amplifiers, 2 stereo amplifiers or one 4 channel amplifier.

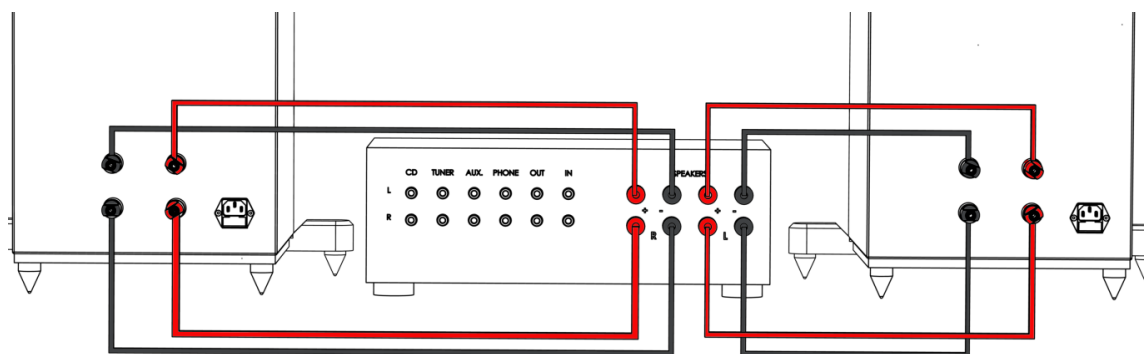

NOTE:

The choice of speaker cables has a major impact on the sound of the system and should therefore be considered carefully. The No.8.3 was developed using high-quality connection cables and should also be operated in your home with the appropriate cables. Please consult with your LANSCHÉ AUDIO dealer to determine which cables are best for your system in order to maximize the sound quality of your No.8.3.

2.4. Operating the Speakers

Switch on the speaker system No.8.3 by activating the power switch **(4)** located near the top at the rear of the speaker cabinet. The indicator light on the power switch **(4)** and the logo **(6)** at the front of the speaker will illuminate light blue and indicate that the control electronics are ready for operation.

The CORONA plasma tweeter starts up automatically after about 45 seconds with a visible plasma ball. This starting process may be accompanied by a clearly audible hiss. After about 45 more seconds the plasma tweeter automatically switches over from the start-up process to normal operating mode. This will be accompanied by a visible reduction in the size of its plasma ball

3. CORONA Plasma Tweeters

3.1. Information about CORONA Plasma Tweeters

- a. The CORONA plasma tweeter emits a bright light (plasma ball) during the start up operation. As with any bright light source avoid looking directly at it from a short distance (less than 30 cm).
- b. Avoid allowing any objects to enter into the CORONA's plasma ball chamber (except for cleaning purpose, see section 3.5 of this manual). This could damage the chamber. When in operation, there is no danger of a hazardous electric shock if a metallic object should accidentally find its way into the chamber (inserted by a child, for example).
- c. During operation, the temperature at the electrode tip is about 800 °C (1,472 °F). Do not allow any kind of material (especially flammable materials) to enter the chamber. Even after switching off, the temperature remains high for at least 30 minutes.
- d. During operation, the horn of the CORONA can heat up to 55 °C (130 °F). Depending on the ambient temperature this can be higher.
- e. CORONA plasma tweeters are highly sensitive electronic devices. Please protect them from mechanical impacts or other mechanical influences.
- f. Particularly during the initial start up phase of operation, it is possible the CORONA will produce some noise. This is due to dust and other stray particles which found their way into its chamber and are being removed.
- g. Never allow air to be blown directly and continuously in to the CORONA's plasma ball chamber. This will produce audible noise and possibly ozone.
- h. Due to the nature of the vacuum tube in the CORONA it is possible it fails to self-start after being powered off for a few minutes. This phenomenon is due to the 'memory effect' of the vacuum tube. Please wait a while and try again.
- i. The self-starting of the CORONA is dependent on the cleanliness of the electrode. If the electrode has not been cleaned recently then a layer of dust and foreign particles will have formed over it. Cleaning will be necessary, see section 3.5 in this manual.
- j. The colour and brightness of the CORONA's plasma ball is dependent on dust and foreign deposits on the electrode, the operating temperature, the air humidity and the electrode's running hours. When the CORONA is in the start up phase its plasma ball can become very bright, this is done deliberately to improve starting and to remove any foreign deposits within its chamber. Periodic cleaning will give the CORONA plasma ball a diffused 'blue-pink-white' colour. However, small differences in colour and brightness are normal. If the plasma ball still remains very bright after the start up phase you should clean the electrode as described in section 3.5 of this manual.
- k. After the starting process has ended the CORONA switches to normal operation (its plasma ball brightness and size is reduced). Please note, it can take a few minutes for the plasma ball to form a complete circle.

**CAUTION:**

Do not move the loudspeaker until the CORONA plasma tweeter has been powered off for at least 15 minutes and cooled down. Some parts when hot are sensitive to shocks.

Tips on using the No.8.3

The CORONA plasma tweeter is able to reproduce the most finest of details which other tweeters such as: diamond, beryllium, electrostatic and ribbon etc. cannot.

The following points should be observed:

- a. When playing SACDs, noises like hiss or multiple tones can sometimes be heard. This is due to the SACD 1 bit, 64Fs format which inherently produces much noise above 50kHz. This noise level depends of the ADC used in recording of the SACD, the SACD player or the separate DSD capable DAC. If your DAC or player has selectable digital filters for SACD (DSD) then by selecting the appropriate filter the noise can be reduced or eliminated. If your SACD player has a 'NORMAL/WIDE' filter switch on the rear panel, switch it to 'NORMAL'
- b. The use of 'switching' or 'digital' amplifiers should be used with caution. Some produce too many switching harmonics which can easily be heard. Also, some analog amplifiers which use switching power supplies can produce this type of noise too.

3.2. Self-starting of CORONA

The method the CORONA produces sounds is by breaking down the surrounding air molecules with high temperature and then modulating the air molecules with a high frequency carrier wave. An electrode with a pointed tip is used to make contact with the air and thus produces a corona discharge (plasma ball).

The self-starting of the CORONA is dependent on the following combined conditions:

- The cleanliness of the electrode.
- The characteristics of the vacuum tube inside the CORONA which generates the high frequency modulation carrier wave.
- The total amount of running hours on the electrode

The self-starting ability of all CORONA plasma tweeters will differ slightly due to the above combined variables.

**CAUTION:**

Never put any fluids, sprays from aerosols or insert other objects in to the CORONA's chamber, when the ion tweeter is turned on, damage will occur.

3.3. Maintenance

Unlike standard tweeter systems, CORONA plasma tweeters have no moveable parts that are subject to aging or wear. However, after a certain period of use, they do require maintenance. The components subject to depletion are the vacuum tube and the electrode. These parts have been designed to function for at least 5,000 hours of operation (depending on environmental conditions). Should a CORONA plasma tweeter require maintenance, we are always able to restore it to a new condition and to introduce any technical improvements.

NOTE:

Please be aware the CORONA plasma tweeter operates at 100% power even when no music is being played. It is therefore recommended that when you are not listening to music you turn off the tweeter power by the power switch **(2)** located near the top rear of the speaker cabinet.

3.4. Removing and Installing a CORONA Plasma Tweeter

How to remove the tweeter:

- a. Switch off the speaker's power and remove its AC plug.
- b. Switch off the source components.
- c. If the CORONA was powered on please let it cool down for 15 minutes.
- e. Only after the LED in the logo **(6)** on the speaker has fully extinguished can you unscrew the three screws supporting the CORONA. Remove the lower center screw last whilst supporting the CORONA's horn with your hand, this avoids stress being put on the CORONA and the cabinet's threaded screw inserts.

Carefully pull out the CORONA (be aware it is connected to a power cable and a speaker cable).

- f. Unscrew the safety ring on the power cable's metal plug and then pull out the plug.
- g. Pull out the black minus speaker cable. Pull out the red plus speaker cable.
- h. When installing, precede in reverse order ignoring step c.

CAUTION:

Let the CORONA cool down for 15 minutes before removing.

NOTE:

CORONA plasma tweeters are highly sensitive electronic devices. Please protect them from mechanical impacts or other mechanical influences.

3.5. Cleaning procedure

The CORONA's electrode which is located in the center of the horn requires periodic cleaning. Over time, dust and other particles leave deposits on it. These deposits will affect the starting of the CORONA, produce noises and make an uneven plasma ball size. It is recommended you perform such cleaning about every month of normal use. More frequent cleaning will be required if the speakers are used in dusty environments, in rooms where windows are often left opened and in high humidity areas.

- a. Make sure the CORONA has been powered off for at least 15 minutes.
- b. Locate the electrode which is dead center in the horn.
- c. Moisten the cotton swab on one side with the enclosed liquid.
You can also use normal methylated spirit.
The cotton swab should be moist but not dripping wet
- d. Carefully insert cotton swab until you feel it touching the electrode.
- d. Turn the cotton swab and anticlockwise 5 rotations with firm pressure.
- e. Remove the cotton swab.
- g. Depending on the amount and hardness of the deposits formed on the electrode you may have to repeat the procedure again.
- h. Wait 15 minutes to be sure that methylated spirits has completely evaporated.
- i. When starting the CORONA after the cleaning procedure there will be some small noises for a while. This is normal and it is the result of very tiny loose deposits being removed.

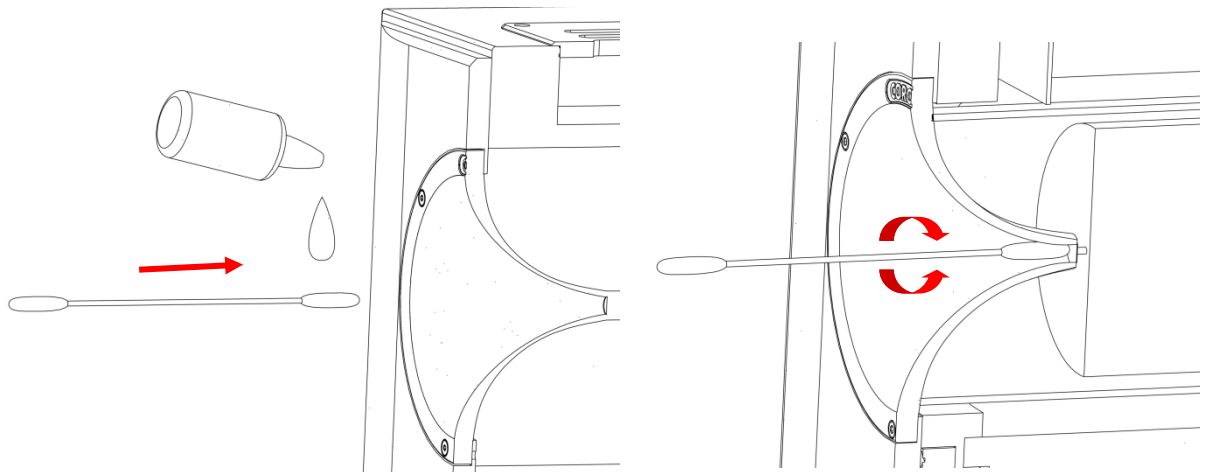
**CAUTION:**

Make sure the Corona has been powered off for at least 15 minutes.

3.6 Fan system

The speaker has an active cooling system integrated.

If the temperature is too high, a warning sound will sound.

There can be two reasons for this

1. The integrated fan has failed
2. The ventilation grille **(2)** is clogged with dust, so that no more cooling takes place

!!! Immediately turn off the speaker. !!!

3.6.1 Control of the ventilation grille (2)

The fan draws in the fresh air through a ventilation grille **(2)** on the rear wall.

This ventilation grille **(2)** can become clogged with dust and must be cleaned regularly. Use a damp microfiber cloth to remove the dust.

The frequency of cleaning depends on the amount of dust in the room.

3.6.2 Replacement fan

The built-in fan has a life expectancy of 200,000 hours.

He turns very slowly because he only has to move the air slowly

If it comes to a defect, then you can easily replace the fan.



CAUTION:

!!! Disconnect the power cable of the loudspeaker !!!

The new fan can come from the PC area. It must have the following specifications to ensure whisper-quiet operation or you can order the original spare part from your dealer

size: 80 x 80 cm
starting voltage: 5 Volt
Speed (12 volts): approximately 1200U/min
PIN: 3

4. Miscellaneous Instructions

4.1. Warm-Up Phase

To develop its maximum potential output, the speaker requires a warm-up period (burn in) of about 15–20 operating hours after being transported. During this time, the properties of all mechanical parts shift until they finally attain the values defined during the development of the speaker. In other words, the suspension of the chassis becomes more flexible, exerting a positive influence on the quality of sound reproduction.

4.2. Load Rating

The load rating of the No.8.3 is especially high due to its design and the materials used in its construction. The speakers can be subjected to very high volumes without a reduction in sound quality (after the warm-up phase). Because of the efficiency of the No.8.3 speakers, they are also suitable for use with high-quality but lower-output amplifiers. However, the following point must be taken into consideration:

Amplifiers with very low output and amplifiers with equalizers or tone controls can produce distorted signals in the higher frequencies at very high volumes. This clipping effect can even permanently damage the best speaker technology. Damage caused in this way is not covered by the warranty.

4.3. Caring for Your Speakers

To get the most out of your LANSCHÉ AUDIO speaker system, please observe the following instructions: Do not place the speakers in direct sunlight.

Avoid extreme temperature fluctuations and protect the components from humidity. Do not clean the housing surfaces with any substances that contain alcohol or are abrasive. Use the lint-free cloth provided instead. Whenever cleaning your system, be sure to switch off the entire chain of devices.

5. Technical Specifications No.8.3

Description:	3-way bass reflex system
Tweeter chassis:	1 x 0,3 in. CORONA plasma tweeter
Midrange chassis:	2 x 6.5" Paper, coated
Bass chassis:	6 x 9" Aluminum, coated
Crossover frequencies:	200 Hz / 2.5 kHz
Impedance:	8 Ω (Minimum 5.6 Ω)
Sensitivity:	92 dB / 1 W / 1 m
Frequency response:	18 Hz - 150 kHz (± 3 dB)
Dimensions (H x W x D)	81.7" x 12.0" (22.8") x 26.4
Weight:	220 kg (485 lbs)

6. General Notes on Safety

1) - Safety and operating instructions

Please read all safety and operating instructions carefully before operating the device. Never open the housing. If any damage occurs, please contact an authorized LANSCHÉ AUDIO dealer. Avoid submitting the switches and connection elements to excessive force.

2) - Warnings

All warnings on the device and in the operating instructions should be complied with specifically.

3) - Power sources

The local voltage must correspond with the voltage indicated on the serial number plate of the No.8.3 which is located on the bottom plate **(7)**. LANSCHÉ AUDIO cannot be held liable for damage caused by operating the device with a different voltage than the one specified.

4) - Protecting the power cable

Power cables are to be laid such that they will not be damaged. Special caution should be given to all plugs, splitters, and points of connection.

5) - Overload

To prevent fire and electric shock, avoid overloading the electric sockets, extension cables, etc.

6) - Ventilation

Never cover the ventilation grille **(2)**. These are cooling vents for the Corona.

7) - Sources of heat

Never place the devices near sources of heat (radiators, heat accumulators, stoves, or other heat-generating devices).

8) - Water and humidity

To prevent the danger of electric shock, a device should never be operated in the vicinity of water or near a bathtub, sink, or swimming pool.

9) - Penetration by objects and liquids

To eliminate dangers from fire or electrical shock, no foreign objects or liquids may be allowed to enter into the housing. Never expose these speakers to rain or very humid conditions.

10) - Cleaning

Before cleaning, disconnect the AC power plug. Generally speaking, the surface of the cabinet need only to be dusted. Never attempt to clean your No.8.3 with a solvent, as this could damage its finish. Please use a clean, dry cloth such as one made from microfiber.

11) – Speaker supports

Never place the speaker on an unstable stand, tripod, bracket, table, or similar object. A falling speaker could seriously injure a child or adult, in addition to damaging the speaker itself. Mount the speakers only according to the dealer's instructions.

12) - Transport

The devices should be transported using great caution. Abrupt stops, exaggerated force, and uneven surfaces can all cause the devices to tip over. Make sure that there are no cables under the carpet that could be damaged by the spikes.

Do not apply excessive force on the spikes when positioning the speakers, as this could cause them to be torn off from the bottom plate. When lifting the speakers, make sure not to injure yourself on the spikes. When you transport your speakers, be absolutely sure to first remove the AC power cable and any other cables connected to the No.8.3. Always apply the pulling force to the plug itself and never to the cable.

13) - When not in use

If the speakers will not be in operation for an extended period of time (for example, during a vacation), disconnect the AC power plug. If a storm is expected, it is also advisable to disconnect the AC power plug and speaker cable to avoid damage caused by lightning.

14) - Service

The user should not conduct any work on the speakers apart from the operations described in these instructions. The speakers are to be opened and repaired by qualified service personnel only.

15) - Damage

The speaker should be immediately switched off and trained personnel should be consulted if:

- a. Power cords or plugs are damaged;
- b. Objects or liquids have found their way into the speaker;
- c. The speaker was exposed to rain.
- d. The speaker does not function properly, despite following the operating instructions. Only adjust the operating elements as described in the instructions. Improper settings of other operating elements can lead to damage that must then be repaired by a qualified technician in order to return the speaker to its normal operating condition;
- e. The device has fallen or been damaged;
- f. The device does not function properly or displays an obvious drop in performance.

16) - Replacement parts

If replacement parts are required, make sure that service technicians use parts recommended by the manufacturer or parts that possess the same technical characteristics as the originals. Unauthorized replacement parts can lead to fire, electric shock, or other hazards.

17) - Mains fuses

The electronic components of the Lansche No.8.3 speaker system are protected against damage in several ways. To prevent fire, use only fuses of the type and rating specified by the manufacturer. The technical data for the fuses in the individual voltage ranges can be found on the label located on the bottom plate.

18) - Magnetic leakage fields

Each device produces a magnetic leakage field. For this reason, we recommend a minimum distance of 0.5 m between the speakers and magnetically sensitive items (televisions, magnetic wristwatches, computer screens, audio and video tapes, etc.).

19) - CORONA plasma tweeters

- a. The CORONA plasma tweeter emits a bright light (plasma ball) during the start up operation. As with any bright light source avoid looking directly at it from a short distance (less than 30 cm).
- b. Avoid allowing any objects to enter into the CORONA's plasma ball chamber (except for cleaning purpose, see section 3.5 of this manual). This could damage the chamber. When in operation, there is no danger of a hazardous electric shock if a metallic object should accidentally find its way into the chamber (inserted by a child, for example).
- c. During operation, the temperature at the electrode tip is about 800 °C (1,472 °F). Do not allow any kind of material (especially flammable materials) to enter the chamber. Even after switching off, the temperature remains high for at least 30 minutes.
- d. During operation, the horn of the tweeter can heat up to 55 °C (130 °F). Depending on the ambient temperature this can be higher.
- e. CORONA plasma tweeters are highly sensitive electronic devices. Please protect them from mechanical impacts or other mechanical influences.